

What Makes the Silencer® 610 EPS12V Up to 90% Quieter Than Other Mid-Wattage Units?

According to the technical literature from leading fan manufacturers, the primary cause of system-related fan noise is air turbulence at the inlet side of the fan.

Turbulence is caused by obstructions in the air stream such as finger guards (PSUs with 120mm fans), or capacitors, heat sinks, etc (PSUs with 80mm fans). The closer the obstruction is to the inlet of the fan, the greater the turbulence. (See Fig.1)

When turbulent air enters the fan, the impact on the blades creates a discrete, high-frequency tone that's particularly annoying and up to 10dB louder than non-turbulent air.

The Silencer 610 is the only computer power supply available today with no obstruction within 1" of the fan inlet! This innovative, ultra-quiet design was achieved by making the Silencer's form factor deeper (1.5"), without sacrificing compatibility with standard ATX computer cases. (See Fig. 2)

Fig. 1

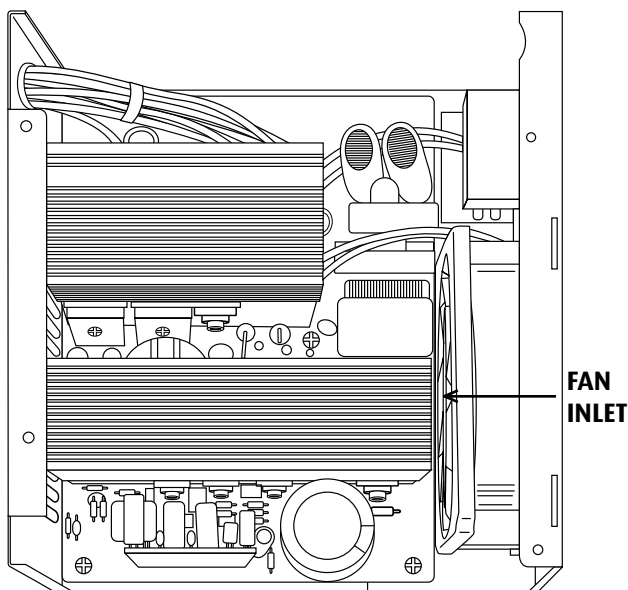

Ordinary power supply with obstructed fan inlet.

Fig. 2

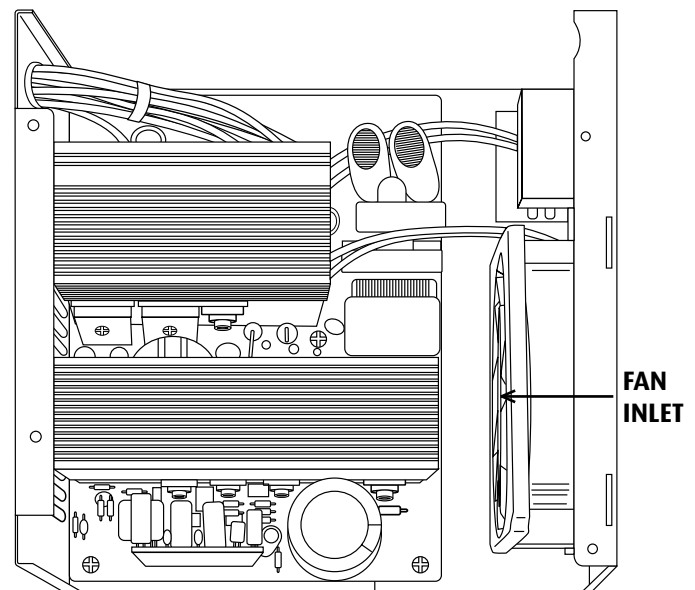

Silencer 610 with noise suppression air gap at fan inlet.

PC POWER & COOLING, INC.®
High-Performance Computer Power Supplies Since 1985

www.pcpower.com • 5995 Avenida Encinas, Carlsbad, CA 92008 • (760) 931-5700 • (800) 722-6555

Components depicted and circuit board layout for illustration purposes only. Silencer and PC Power and Cooling are registered trademarks of PC Power & Cooling, Inc. ©2006